

**ROOFING APPLICATION STANDARD (RAS) No. 111
STANDARD REQUIREMENTS FOR ATTACHMENT OF PERIMETER
WOODBLOCKING AND METAL FLASHING**

1. Scope

1.1 This Application Standard provides:1) the minimum criteria for attachment of perimeter and termination woodblocking; and 2) the minimum criteria for material fabrication and attachment of perimeter metal flashing.

2. Definitions

2.1. For definitions of terms used in this application standard, refer to ASTM D 1079; and the *Florida Building Code, Building*.

3. Woodblocking Attachment

3.1. Wood blocking shall be attached to resist wind forces, and other loads, as required by Chapter 16 (High-Velocity Hurricane Zones) of the *Florida Building Code, Building*.

3.2 Fastener value (f_v)

3.2.1 Fasteners/anchors which have published withdrawal resistance values, generated from laboratory testing, shall have a margin of safety, as noted in Table 1, below, applied to average laboratory test results.

- Use of published withdrawal resistance values to determine a fastener value for a particular application shall be contingent upon the similarity of substrate materials which generated the published values in comparison to the substrate material of the actual application.

3.2.2 Alternatively, the Fastener Value may be the result of in situ (on-site) testing, in compliance with TAS 105, resulting in a minimum characteristic resistance force which shall be used as the Fastener Value.

TABLE 1 MARGINS OF SAFETY FOR LABORATORY WITHDRAWAL RESISTANCE TESTING	
Substrate	Margin of Safety
Steel Decking	2:1
Concrete Decking	4:1
Wood Decking	2:1
Gypsum Decking	3:1
Cementitious Wood	
Fiber Decking	3:1
Structural Steel	2:1

3.3 Woodblocking Fastener Spacing

3.3.1 The attachment criteria for woodblocking shall be 250 plf for perimeter areas and 300 plf for corner areas.

3.3.2 In any event, woodblocking fastener spacing shall not exceed 18 in. o.c.

3.4 Woodblocking attachment, general requirements:

3.4.1 In recover, or residential wood decks applications, woodblocking thickness may be reduced to 1 in., provided the attachment is in compliance with the provisions of Chapter 16 (High-Velocity Hurricane Zones) of the *Florida Building Code, Building*.

3.4.2 The maximum unsupported overhang of the woodblocking shall not exceed 2 in. If the maximum overhang is employed, the minimum woodblocking dimensions shall be not less than a nominal 2 in. by 8 in. and two rows of fasteners shall be installed in a staggered manner.

- 3.4.3 A fastener shall be placed within 3 in. of the end of each section of woodblocking, and a $\frac{1}{4}$ in. gap shall be left between each section of woodblocking.
- 3.4.4 All fastener/anchor heads shall be countersunk or fastener/anchor heads shall be driven flush with the top surface of the woodblocking.
- 3.4.5 All woodblocking, shall be only salt pressure treated in accordance with the American Wood Preservers Association, C-2 or C-9, or any decay resistant species.
- 3.4.6 If the woodblocking thickness is greater than that of the insulation a tapered edge shall be installed to create a sloped transition between the insulation and the woodblocking.
- 3.4.7 All fasteners/anchors used for attachment of woodblocking shall meet the corrosion resistance requirements set forth in Appendix "E" of TAS 114 for insulation and membrane fasteners (DIN 50018).
- 3.4.8 When the width of the woodblocking is greater than 6 in. anchors shall be staggered in two rows across the woodblocking width.
- 3.5 Woodblocking Attachment, Masonry Block
- 3.5.1 When the masonry block is cast with lightweight aggregate, anchor bolts shall be embedded not less than 6 in. into the second course of block.
- 3.5.2 If expansion bolts are substituted for $\frac{1}{2}$ in. diameter cast in place anchor bolts, the minimum expansion bolt diameter shall be $\frac{3}{8}$ in.
- 3.6 Woodblocking Attachment, Structural Concrete
- 3.6.1 Anchors used for woodblocking attachment to structural concrete shall have a nominal diameter of 0.250 in.; therefore, a threaded concrete anchor or insulation fastener with a nominal $\frac{1}{4}$ in. diameter shall be acceptable.
- 3.6.2 Powder actuated (PAT) fastening (Pins and Loads) shall not be an acceptable method of attachment.
- 3.7 Woodblocking Attachment, Steel Decking
- 3.7.1 All fasteners shall penetrate the top flange of the steel deck.
- 3.7.2 When woodblocking is attached parallel to the deck flutes, the steel decking shall be mechanically attached to the structural steel with minimum $\frac{1}{4}$ in. diameter self-tapping or self-drilling fasteners with a minimum $\frac{5}{8}$ in. diameter bearing washer, at a maximum spacing of seven feet o.c. prior to the attachment of the woodblocking.
- 3.7.3 If the steel deck thickness is less than 22 gage, a withdrawal resistance test, in compliance with TAS 105, shall be conducted to determine compliance with Chapter 16 (High-Velocity Hurricane Zones) of the *Florida Building Code, Building*.
- 3.8 Woodblocking Attachment, Lightweight Decks
- 3.8.1 For the purposes of this section, "lightweight decks" shall include gypsum, cementitious woodfiber and lightweight insulating concrete decks.
- 3.8.2 Lightweight decks should not be used as a woodblocking attachment substrate unless:
- The selected woodblocking anchor is fastened to the underside of the deck or attached directly to a structural member.
 - The selected woodblocking anchor can achieve an average withdrawal resistance of not less than 450 lbf tested in compliance

with TAS 105.

3.8.3 Toggle bolts are not acceptable woodblocking fasteners for any type deck.

3.8.4 Fastener spacing for wood blocking shall not exceed 12 inches o.c.

4. Galvanic Action

4.1 Components shall be compatible to minimize the potential for galvanic corrosion. Galvanic corrosion will occur when dissimilar metals come into contact with an electrolyte. An electrolyte is any nonmetallic substance (especially liquid) that will conduct electric current. Water is an electrolyte. Metals that are more electro-positive (anodic or least noble) and will corrode more easily are at one end of the scale. Those that are more electro-negative (cathodic are more 'noble') and are more corrosion resistant are at the other end of the scale.

4.2 Common metals used in metal roof construction in order of least noble to more noble are as follows:

- Anodic (least noble)
- Magnesium
- Magnesium Alloys
- Zinc
- Galvanized Coated Steel
- Aluminum 1100
- Alclad
- Cadmium
- Mild Steel
- Wrought Iron
- Cast Iron
- 13 percent Chromium Stainless Steel (Type 410 active.)
- 18-8 Stainless Steel (Type 304 active.)
- 18-12-3 Stainless Steel (Type 316 active.)
- Lead / Tin Solder
- Lead
- Tin
- Muntz Metal
- Manganese Bronze
- Naval Brass
- Nickel (active)
- 76 Ni-16 Cr-7 Fe alloy (active)

- 60 Ni-30 Mo-6 Fe-1 Mn
- Yellow Brass
- Admiralty Brass
- Aluminum Brass
- Red Brass
- Copper
- Silicone Bronze
- 70:30 Cupro Nickel
- G-Bronze
- M-Bronze
- Silver Solder
- Nickel (passive)
- 76 Ni-16 Cr-7 Fe alloy (passive)
- Monel
- 13 % Chromium Stainless Steel (Type 410 passive)
- Titanium
- 18-8 Stainless Steel (Type 304 passive)
- 18-12-3 Stainless Steel (Type 316 passive)
- Silver
- Graphite
- Gold
- Platinum
- Cathodic (more noble)

4.3 To reduce the occurrence of galvanic corrosion, the following steps shall be taken:

- Do not place metals far apart in the scale in contact with each other. Fasteners shall be of compatible materials.
- The more noble (cathodic) metal may be coated with a suitable paint or non-metallic coating.
- Do not design drainage from a cathodic to anodic metal even if materials do not make contact. The water will conduct electrical current between the two materials.
- Galvanized nails shall not be used to attach copper metal.

4.4 Flashing gages:

4.4.1 Table 2 lists material thickness requirements based on edge metal component dimensions for roof mean

TABLE 2 HOOK STRIP/CONTINUOUS CLEAT THICKNESS REQUIREMENTS FOR EDGE METAL AND COPINGS FACE DIMENSIONS						
GALVANIZED METAL OR STAINLESS STEEL						
Min. Component Gage		26 ga	24 ga	22 ga	20 ga	18 ga
Max. Vertical (Face) Flange		4 in.	6 in.	8 in.	10 in.	12 in.
Min. Hook Strip/Cleat Gage ¹		24 ga	22 ga	20 ga	18 ga	16 ga
ALUMINIM						
Min. Component Gage	0.032 in.	0.032 in.	0.040 in.	0.050 in.	0.060 in.	0.070 in.
Max. Vertical (Face) Flange	< 3 in.	3 in.	4 in.	6 in.	8 in.	10 in.
Min. Hook Strip/Cleat Gage	Not Required	0.040 in.	0.050 in.	0.060 in.	0.070 in.	0.080 in.
COPPER						
Min. Component Gage			16 oz	20 oz.	24 oz.	32 oz
Max. Vertical (Face) Flange			3.5 in.	6 in.	8 in.	10 in.
Min. Hook Strip/Cleat Weight ¹			20 oz.	24 oz.	32 oz	48 oz

For SI: 1 inch = 25.4 mm.

¹Hook strip shall be one thickness greater than that of the metal profile material, as commercially available.

height less than 54 ft. For roof mean height of 54 ft. or greater flashing terminations shall be designed by a professional engineer or registered architect proficient in roofing design. Calculations in compliance Chapter 16 (High-Velocity Hurricane Zones) of the *Florida Building Code, Building* shall be submitted with Section II of the Uniform Building Permit Application to the building official for review.

- 4.4.2 All edge metal profiles, copings, and coping caps shall comply with Table 2 herein. The maximum vertical (face) dimension listed in Table 2 represents the vertical (face) dimensions where a hook strip is required. Smaller vertical (face) dimension than those listed in Table 2 edge metal profiles and copings of the specified gauge may be used without a hook strip.

5. Drip Edge and Gravel Stop

- 5.1 Minimum attachment shall include horizontal flange attachment with approved minimum 12 ga. annular ring shank nails at a spacing not to exceed 4 in. o.c. in a staggered pattern. Rows shall be approximately $\frac{3}{4}$ in. to 1 in. from each edge of the horizontal flange. Nails shall be fabricated from similar or compatible material to the drip edge/gravel stop.
- 5.2 Installation requirements:
- 5.2.1 Vertical flange dimensions shall be not less than $1\frac{1}{2}$ in. and the horizontal dimension shall not be less than 2 in. wide. The vertical flange shall be of sufficient length to extend below the sheathing or other member immediately contiguous thereto by not less than $\frac{1}{2}$ in. Table 2 herein lists maximum vertical flange di-

mensions for various drip edge/gravel stop materials.

5.2.2 Drip edge/gravel stop shall be fabricated in lengths not greater than 12 feet. Sections may be joined by one of the two following methods:

- **“Butt-Joint” Method:** Drip edge/gravel stop sections shall be installed with a 1/4 in. to 1/2 in. gap between each section to allow for expansion and contraction of the metal. A back or cover plate shall be installed at each joint with approved sealant applied between the edge component and the back or cover plate.
- **“Overlap” Method:** Drip edge/gravel stop sections shall be installed with a minimum 4 in. overlap between each section with a bed of approved sealant at each overlap. Overlaps are to be installed to ensure water shedding capabilities at rakes/gables.

5.2.3 When a continuous cleat (hook strip) is required and the vertical flange exceeds 7 in. the “butt-joint” method

shall be utilized and a cover plate shall be installed.

NOTE: All metal surfaces receiving hot bitumen approved flashing cement shall be fully primed with ASTM D 41 or ASTM D 43, as required, primer. Primer which is in a quick dry formulation is acceptable. All fasteners shall be covered with either:

- Two layers of “stripping” or “flashing” felt set in hot asphalt or approved flashing cement; or,
- A single layer of modified bitumen, torch applied or set in hot asphalt, or approved adhesive.

Exception: Drip edge for asphalt shingle roof systems need not comply with this section.

5.2.4 The continuous cleat (hook strip) minimum attachment installation shall be as follows:

- The cleat shall be attached to the vertical face of the woodblocking or structure using approved 12 ga annular ring shank nails or # 10 diameter fasteners spaced not greater than 10 in. o.c. at perimeter roof areas and 6 in. o.c. at corner roof areas.

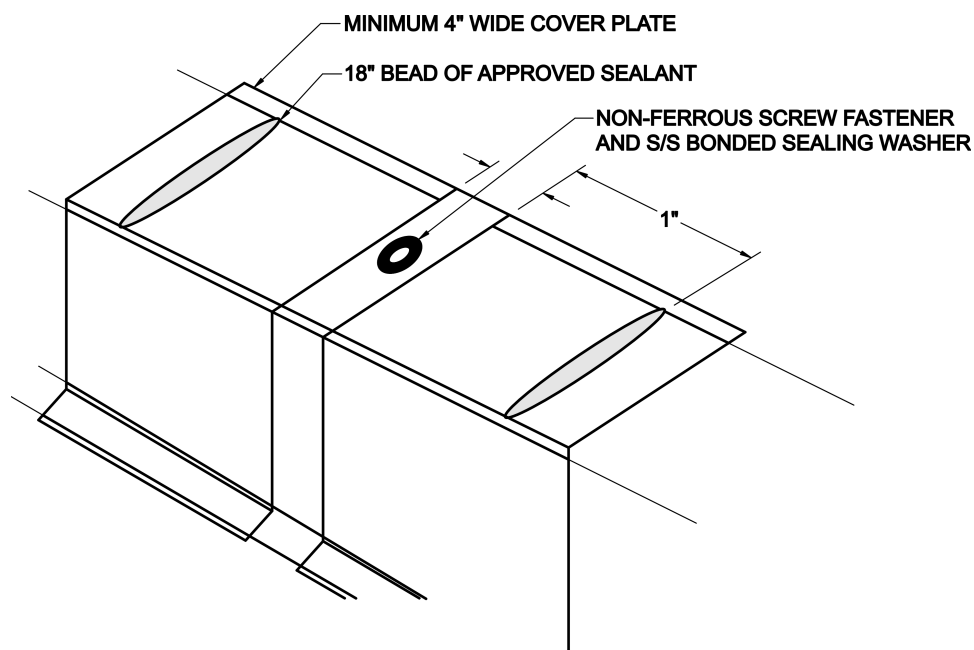

FIGURE 1
DETAIL OF “BUTT-JOINT” METHOD FOR ADJACENT DRIP EDGE/GRAVEL STOP SECTIONS

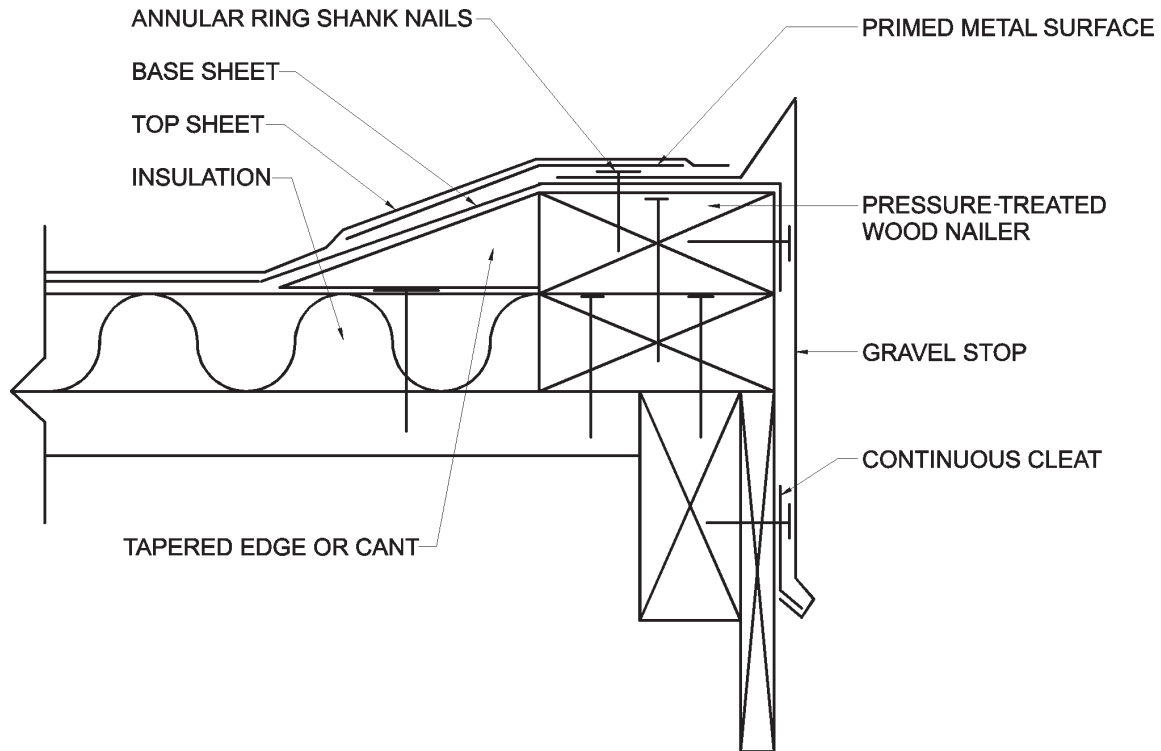

FIGURE 2
EXAMPLE OF RAISED EDGE AT GRAVEL STOP PERIMETER FLASHING

- Nails shall be fabricated from similar or compatible material to that of the continuous cleat, and shall be of sufficient length to penetrate the substrate by not less than $1\frac{1}{4}$ in. and shall have a minimum head size of $\frac{5}{16}$ in.
- Nylon or plastic anchors shall not be acceptable.

5.2.5 Notwithstanding the minimum attachment criteria noted herein, metal edge systems of any dimension may be tested in compliance with TAS 111(A) and TAS 111 (B), the values from which may be submitted with Section II of the Uniform Building Permit application to the building official for review.

5.2.6 Heavy, extruded drip edge/gravel stop sections may be used provided a horizontal flange of a lesser thickness is incorporated into the edge metal configuration (see Figure 4).

5.2.7 Where the drip edge/gravel stop forms part of a metal roof system, the following provisions apply:

- The drip edge/gravel stop shall be secured to the profile metal sheeter structural members with sufficient anchors/fasteners to resist wind forces determined in compliance with Chapter 16 (High-Velocity Hurricane Zones) of the *Florida Building Code, Building* and in accordance with RAS 111 and 133.
- All fasteners shall be fitted with minimum $\frac{5}{8}$ in. o.c. bonded sealing washers, unless otherwise noted in the roofing assembly Product Approval.
- Continuous clips (hook strips) shall be required as noted in Table 2 herein.

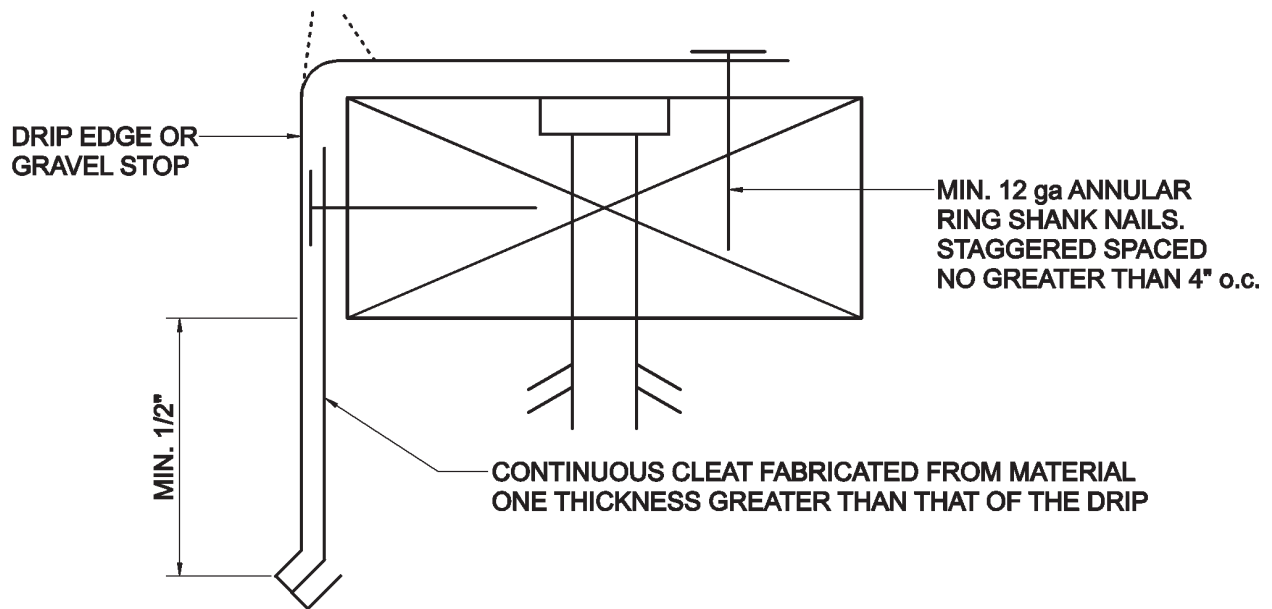

FIGURE 3
EXAMPLE OF A PERIMETER FLASHING FOR CONFIGURATIONS INCLUDING A CONTINUOUS CLEAT

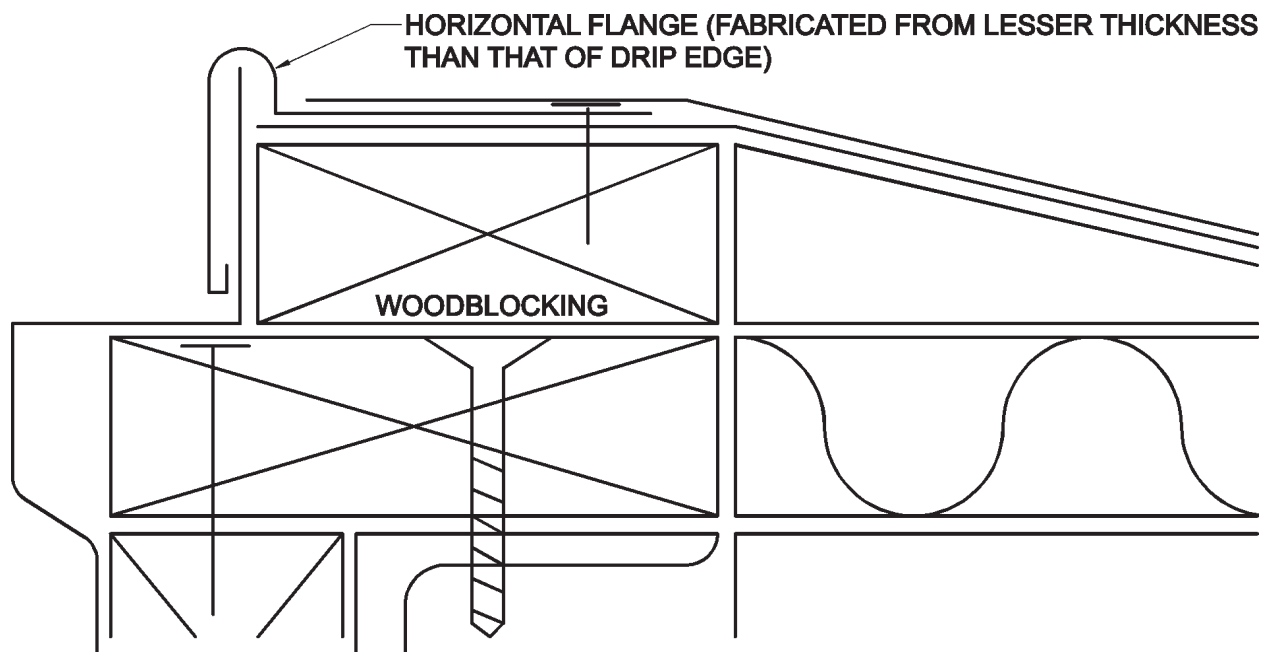

FIGURE 4
USE OF HEAVY EXTRUDED GRAVEL STOP WITH HORIZONTAL FLANGE OF LESSER THICKNESS

6. Metal Profiles, Copings, & Coping Caps

6.1 All metal profiles, copings, and coping cap attachments must resist wind induced outward and upward forces which attempt to lift or peel the edge system from its attachment points, in compliance with Chapter 16 (High-Velocity Hurricane Zones) of the *Florida Building Code, Building*.

6.2 The metal profiles, copings, and coping caps and their attachments shall be designed to meet design pressures in compliance with Chapter 16 (High-Velocity Hurricane Zones) of the *Florida Building Code, Building* and shall be tested in compliance with TAS 111(A), TAS 111(B) and TAS 111C to confirm compliance.

6.2.1 Criteria for vertical flange dimension, material type, thickness, and requirements for use of a continuous cleat (hook strip) are noted in Table 2 herein.

6.3 Installation Requirements

6.3.1 The vertical flange of metal profiles and coping caps shall be of sufficient length to extend below wood blocking by not less than $\frac{1}{2}$ in.

6.3.2 At corners, metal profiles, copings, and coping caps may be formed, mitered, lapped, notched, sealed, welded or soldered as necessary to provide a continuous system that is not more susceptible to leaks than straight sections.

6.3.3 Notwithstanding other requirements set forth in this application standard,

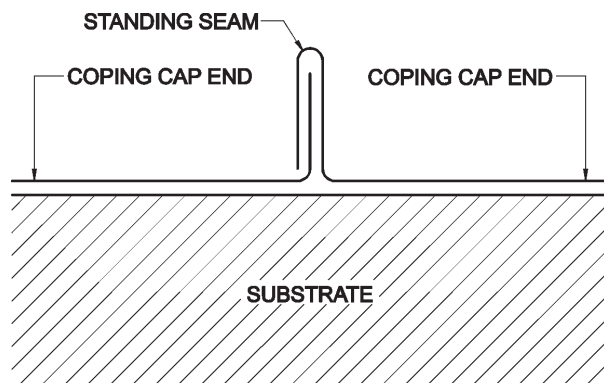

one said fastener shall be installed not more than 1 in. from the end of each metal profile section where sections are joined with a splice plate.

6.3.4 For metal profiles copings and coping cap applications which require a continuous cleat (hook strip), minimum attachment requirements are as follows:

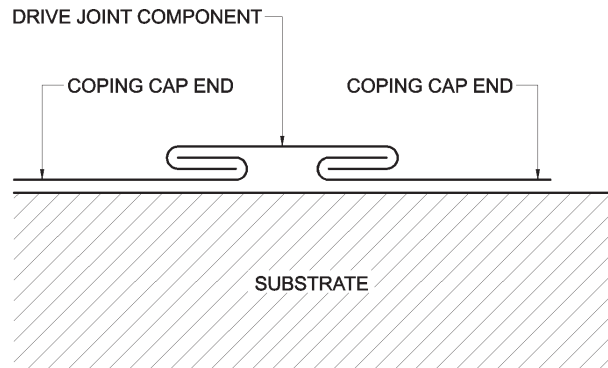

- The cleat shall be attached to the vertical face of the woodblocking using approved 12 ga. annular ring shank nails or # 10 diameter fastener spaced not greater than 10 in. o.c. at perimeter roof areas and 6 in. o.c. at corner roof areas.

- Nails shall be fabricated from similar or compatible material to that of the continuous cleat, shall be of sufficient length to penetrate the substrate by not less than $1\frac{1}{4}$ inches (32 mm) and shall have a minimum head size of $\frac{5}{16}$ in.

- Nylon or plastic anchors shall not be acceptable.

6.4 Coping Caps

6.4.1 Coping caps shall slope toward the roof.

6.4.2 Coping caps shall be fabricated in lengths not greater than 12 feet. Sections may be joined as described above or using one of the following configu-

rations which eliminate splice plates and overlaps.

6.4.2.1 Standing Seam Configuration

6.4.2.2 The Drive Configuration below allows use of a thinner material for the drive joint components than that of the coping sections.

7. Counter-flashing

7.1 For material and thickness requirements see Table 2 herein. Alternatively, counter-flashing manufacturers may obtain Product Approval.

7.2 General Attachment Requirements

7.2.1 Joints in counter-flashings shall be overlapped a minimum of 4 in. or as stated in counter-flashing Product Approval. Corners shall be mitered and soldered or sealed with an approved sealant. At corners, counter-flashings may be formed, mitered, lapped, notched, sealed, welded or soldered as necessary to provide a continuous system that is not more susceptible to leaks than straight sections.

7.2.2 Counter-flashing attachment points shall be elevated not less than 8 in. above the finished roof surface. Where existing job conditions do not allow

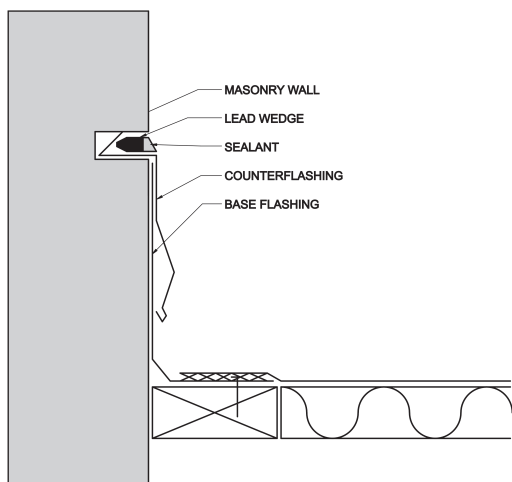

FIGURE 5
EXAMPLE OF REGLET MOUNTED COUNTER-FLASHING

counter flashing to be 8 in. above finished roof surface, the counter flashing may terminate 4 in. above the finished roof surface. Parapets less than 8 in. above finished roofing must be flashed to the outside edge and include a metal flashing which extends minimum 1 in. below the finished exterior system.

7.2.3 The lower edge of a counter-flashing shall be not less than 1 in. above the top edge of the cant or, when no cant is present, the finished roof surface.

7.2.4 Counter-flashing shall not be a continuous piece across moving wall joints.

7.2.5 Anchors shall provide a minimum characteristic resistance force of 150 lbf, tested in compliance with TAS 105 or an average withdrawal resistance of 150 lbf resulting from laboratory testing after a 2:1 margin of safety is applied. Anchors shall be fitted with a minimum $\frac{7}{8}$ in. o.d. bonded sealing washer, having a minimum 0.060 in. gasket thickness, and shall be installed through slotted or oversized holes at a spacing not greater than 8 inches (203 mm) o.c.

7.2.6 Surface mounted flashing shall have a flat surface for flush wall mounting of not less than $1\frac{1}{2}$ in. and not greater than $2\frac{1}{2}$ in. The flashing profile may include stiffening bends at top and bottom. The total of the two bends shall exceed 90 degrees.

7.2.6.1 When an expansion joint occurs at a base flashing, additional counter-flashing attachment shall include:

- A mechanical lock at a two piece reglet; or,
- A reinforcing bar, of similar or compatible material, at the mechanical attachment point to distribute load.

7.3 Reglet-mounted counter-flashings:

7.3.1 If a reglet-mounted counter-flashing is to be used, the joint shall be in accordance with reglet counter-flashing manufacturer's recommendations.

The counter-flashing may be held in place by spring action wedges and sealant. Reglets shall not be cut into hollow cells of masonry walls or concrete.

7.4 For surface mounted reglet-type counter-flashing applications, the following provisions shall apply.

7.4.1 A bead of approved sealant shall be applied at the top edge to create a waterproof seal. Sealant shall be installed in accordance with the sealant manufacturers published literature. Primer shall be applied to the substrate material when recommended by the sealant manufacturer. Sealant shall have two-point adhesion; to the reglet and to the wall substrate for maximum sealant performance. Bond breaker or backer rod shall be installed where necessary to create two-point adhesion. Refer to the sealant manufacturer's published literature for specific types of bond breaker or backer rods.

7.5 Stucco Counter-flashing

7.5.1 Stucco counter-flashing, or "stucco stops," may be fabricated in one- or two-piece configurations or may have

Product Approval as a roofing component.

7.5.2 Material thickness and dimension requirements shall comply with Table 2. Alternatively, counter-flashing manufacturers may obtain Product Approval.

7.5.3 Stucco counter-flashing shall be overlapped a minimum of 4 in. or as stated in counter-flashing Product Approval.

7.5.4 Attachment requirements:

7.5.4.1 Anchors shall provide a minimum characteristic resistance force of 100 lbf, tested in compliance with TAS 105 or an average withdrawal resistance of 100 lbf resulting from laboratory testing after a 2:1 margin of safety is applied. Anchors shall be fabricated from similar or compatible material to that of the stucco counter-flashing and shall be installed through slotted or oversized holes at a spacing not greater than 12 in.

7.5.4.2 Where the stucco counter-flashing is attached to steel or wood

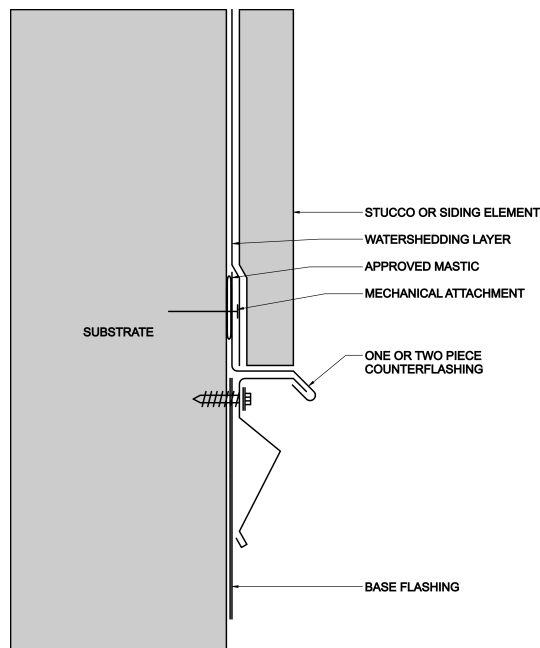

FIGURE 6
EXAMPLE OF STUCCO COUNTER-FLASHING

studs, attachment shall be at each stud with a minimum #8 diameter fastener providing a minimum characteristic resistance force of 150 lbf, tested in compliance with TAS 105 or an average withdrawal resistance of 150 lbf resulting from laboratory testing after a 2:1 margin of safety is applied.

7.5.5 Stucco counter-flashing attachment points shall be elevated not less than 8 in. above the finished roof surface. Where existing job conditions do not allow stucco counter flashing to be 8 inches above finished roof surface, the counter flashing may terminate 4 in. above the finished roof surface. Parapets less than 8 in. above finished roofing must be flashed to the outside edge and include a metal flashing which extends minimum 1 in. below the finished exterior system.

7.5.6 The base water shedding layer behind the stucco or siding element, where required, shall terminate over top of the vertical leg of the stucco counter-flashing. Vertical leg of the stucco counter-flashing shall be set in a bed of

approved mastic prior to mechanical attachment or sealed in a three course application of asphalt based mastic and minimum 4 in. wide fiberglass membrane following mechanical attachment (see Figure 6).

8. Metal Panel Flashings (Sill Flashings)

8.1.1 Material thickness and dimension requirements shall comply with Table 2 herein. Alternatively, counter-flashing manufacturers may obtain Product Approval.

8.1.2 All metal wall panels shall be closed with a foamed, or other type of compressible, closure strip approved for use with the panel profile in the roof assembly Product Approval.

8.1.3 Sill flashing may be one- or two-piece flashing forming a panel termination or forming a counter-flashing for a roof system assembly base flashing. Flashing shall be fastened with minimum approved annular ring shank roofing nails at a spacing not to exceed 12 in. o.c.

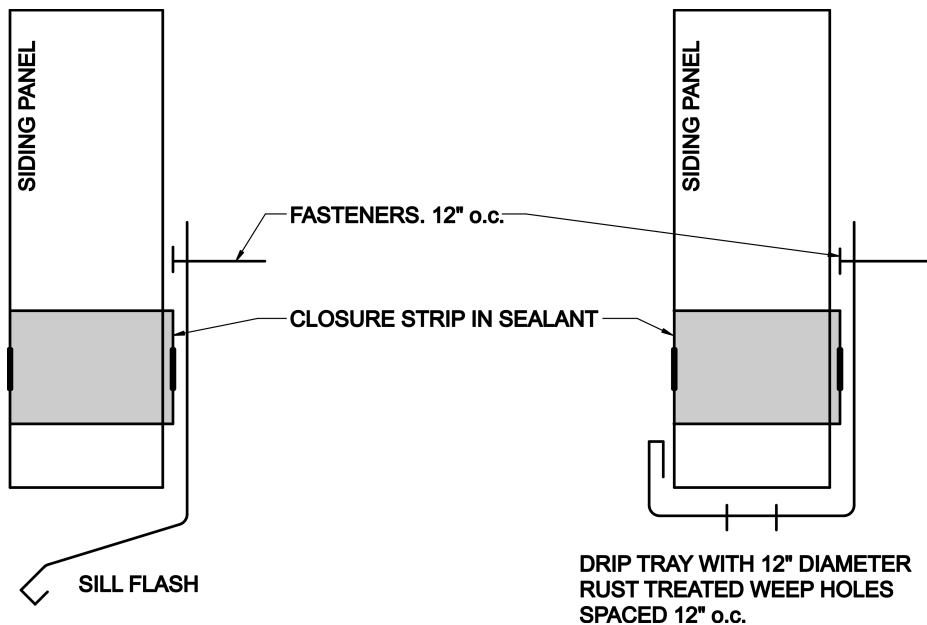

FIGURE 7
TYPICAL SILL FLASHING CONFIGURATIONS

- 8.1.4 Weep trays shall have $\frac{1}{2}$ in. min. diameter weep holes at a spacing not to exceed 12 in. o.c. The weep holes shall be treated to prevent corrosion.
- 8.1.5 Metal wall panels may be terminated with similar flashing to those noted herein.
- 8.1.6 Typical sill flashing configurations are noted in Figure 7, below.

9. Membrane Base Flashing

9.1 Minimum flashing shall consist of a base layer of ASTM D 226, Type II; ASTM D 4601, Type II; ASTM D 2626 base ply; or ASTM D 4897, bonded to a primed vertical surface with type IV asphalt or an approved cold adhesive or flashing cement. The base ply shall be covered with one interply of a like material to the base ply, bonded in Type IV asphalt or an approved cold adhesive or flashing cement. The top flashing ply shall be a coated or granule surfaced membrane of a material compatible with the base ply, bonded in Type IV asphalt or an approved cold adhesive or flashing cement. The top flashing

ply shall have either a granular surface or be coated with an approved aluminized or emulsion coating to meet the fire classification and to resist ultraviolet exposure.

- 9.2 Membrane base flashings shall be mechanically attached with a continuous metal termination bar at 6 in. o.c to the vertical wall. Such termination bar shall be placed no more than $1\frac{1}{2}$ in. down from the upper edge of the membrane flashing. Membrane flashing shall terminate under a metal counter flashing or be finished with a metal surface mounted reglet attached to the wall at a spacing not to exceed 8 in. on center. The reglet shall be weatherproofed with a caulk bead of a suitable type to bond to both the metal reglet and the wall surface.
 - 9.2.1 Anchors shall provide a minimum characteristic resistance force of 150 lbf, tested in compliance with TAS 105 or an average withdrawal resistance of 150 lbf resulting from laboratory testing after a 2:1 margin of safety is applied, and shall be installed through slotted or oversized holes.
- 9.3 Membrane base flashings shall not be less than 8 in. above the finished roof surface. Where existing job conditions do not al-

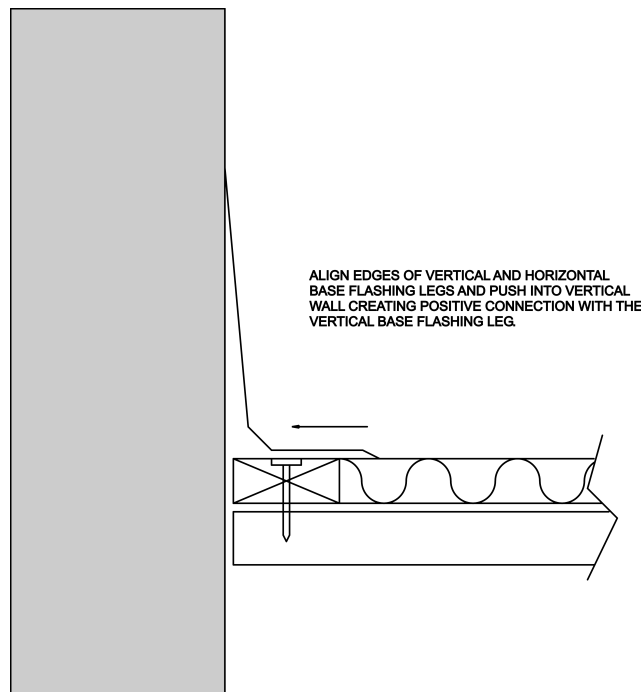

FIGURE 8
METAL BASE FLASHING CONNECTION WITH VERTICAL WALL

low membrane base flashing to be 8 in. above finished roof surface, the counter flashing may terminate 4 in. above the finished roof surface.

- 9.4 Membrane base flashings shall be continuous across the transition between the wall and roof.
- 9.5 All vertical junctions shall be provided with a cant strip. Base flashing shall extend a minimum of 8 in. above finished roofing. Membranes shall not be angled up or down greater than 45 degrees where exposed as part of the waterproofing layer unless specifically detailed in roof assemblies published literature. Published detailed drawings shall be submitted with the Uniform Building Permit Application to the building official for review.
- 9.6 In nonasphaltic single-ply roofing installation, metal base flashings or perimeter drip edge/gravel stop may be sealed with proprietary bonding methods, such as coated metal for thermoplastic welding or contact adhesives to bond membrane to prepared metal or other surfaces, in accordance with roof assemblies manufacturer's published literature. Metal terminations shall be secured in compli-

ance with the provisions herein and in compliance with Chapter 16 (High-Velocity Hurricane Zones) of the *Florida Building Code, Building*.

- 9.7 Bituminous roofing systems may be terminated by multiply felts, modified bitumen flashing, or in accordance with roof assemblies manufacturers published literature. When asphaltic systems are bonded to metal, all metal shall be fully primed with ASTM D 41 primer. Metal terminations shall be secured in compliance with the provisions herein and in compliance with Chapter 16 (High-Velocity Hurricane Zones) of the *Florida Building Code, Building*.

10. Termination Bars

- 10.1 Termination bars may be fabricated in a variety of shapes and profiles and should be fabricated from materials having a high stiffness coefficient to evenly distribute the loads incurred on fasteners. Termination bars shall be a minimum thickness of 1/8 in.
 - 10.1.1 Holes in the termination bar shall be slotted or oversized to allow for dimensional changes in the metal.

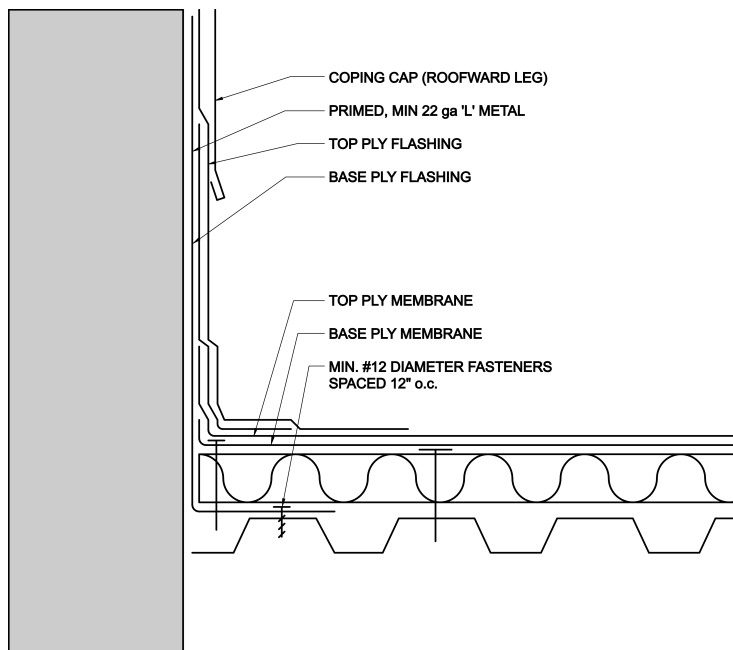

FIGURE 9
EXAMPLE OF ADHERED MEMBRANE ROOF SYSTEM ASSEMBLY TERMINATION

10.1.2 All termination bars shall be tested for corrosion resistance in compliance with Appendix E of TAS 114. (DIN 50018).

10.2 Minimum attachment requirements for termination bars shall include the following.

- All termination bar fasteners or anchors shall have a minimum $\frac{1}{4}$ in. diameter. Anchors shall provide a minimum characteristic resistance force of 180 lbf, tested in compliance with TAS 105 or an average withdrawal resistance of 180 lbf resulting from laboratory testing after a 2:1 margin of safety is applied, and shall be installed through slotted or oversized holes at a spacing not greater than 8 in. o.c. except as required in Section 9.2. At the discretion of the building official a field withdrawal resistance test in compliance with TAS 105 may be required to confirm performance.
- All termination bar fasteners or anchors shall be fabricated from similar or compatible material to that of the termination bar.
- A nonferrous metal bonded sealing washer shall be installed under the head of each fastener or anchor if the fastener head is left exposed. Fasteners used in the installation of termination bars to be covered by counter flashing shall not require bonded sealing washers.
- A continuous bead of approval sealant shall be applied under or at the top edge of the termination bars, which are not covered by counter flashing.
- Nylon or plastic anchors shall not be acceptable.

11. Metal base flashing

11.1 Metal base flashings shall be fabricated at an angle slightly greater than 90 degrees to create an adequate connection between the vertical leg and the adjoining vertical wall (see Figure 8).

11.2 Adhered single-ply or modified bitumen roof system assemblies not requiring a cant may be terminated at a primed, minimum 22 ga “L” metal secured to the deck (see Figure 9).

11.3 Metal base flashings for metal roofing systems shall comply with requirements of RAS 133 and those listed herein.

12. Gutters

12.1 Gutters, down spouts, and hold down components shall be secured to resist the load of gravity when full with rainwater in addition to the design wind loads of Chapter 16 (High-Velocity Hurricane Zones) of the *Florida Building Code, Building*.

12.2 Gutters, and down spouts, shall be sized in compliance with Chapter 11 of the *Florida Building Code, Plumbing*.

12.3 Gutters, down spouts, and hold down components shall be constructed in accordance with the Sheet Metal and Air Conditioning Contractors National Association, Inc. (SMACNA) *Architectural Sheet Metal Manual*, 5th edition. In addition to the following requirements:

12.3.1 Gutter joints shall be lapped 4 in. sealed with two rows of approved sealant, and riveted with two rows of closed end rivets offset 1 in. o.c.

12.3.2 Maximum gutter lengths shall not exceed 50-ft. Gutter ends shall not be butted tight to a wall or other obstruction, which may prevent thermal expansion of metal.